

TUNE IN TOKYO v1.2

sound effect synthesizer
ericarcher.net / devices / tit

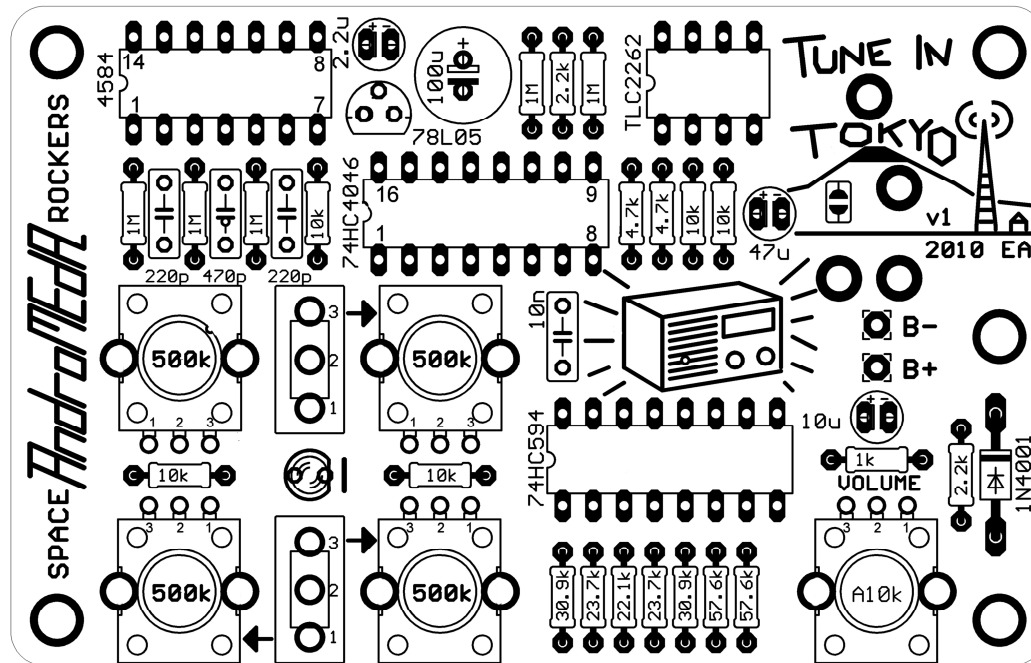

Tune In Tokyo simulates the swirling, whistling sound of tuning an old-fashioned radio.

The kit includes all parts necessary. Previous soldering experience recommended.

The circuit has a 1/4" line level output. You'll need a 9V battery and amplifier to hear it.

Use the 4 knobs & 2 switches clustered around the LED to control the sound. The VOLUME knob is located on the right side of the board.

The switches select which knob is active. This is indicated with arrows that point from the switch to the knobs. The middle knob on the bottom row is the Low Frequency Oscillator (LFO) and automatically scans through the frequencies when selected.

This kit is an enclosure-less design.

If you'd like to build Tune In Tokyo into an enclosure, don't use the potentiometers and switches included. You can get panel-mount controls from an electronics distributor, and mount them in the enclosure of your choice. Connect them to the circuit board with insulated wire. You'll also need a panel-mount 1/4" jack.

TUNE IN TOKYO

sound effect synthesizer

aliased/decimated sine waves
(complex frequency source)
built-in low frequency osc

Tools you need for this kit

- Soldering iron (25W - 40W, narrow tip)
- Flush cutting pliers
- Serrated jaw pliers and Philips screwdriver
- Bright work light



You're about to solder all of the components to the circuit board. Check your soldering iron now. Touch the tip of the iron to some fresh solder. It should melt immediately with a puff of smoke and cling to the tip like a drop of water. Wipe the solder off the tip on a damp sponge. The tip should be shiny. Some cheap soldering irons have tips that solder won't cling to. Its difficult to make quality connections with this type.

After you solder a component, trim its leads flush with the bottom of the board. Wipe the tip of the soldering iron clean on a damp sponge frequently.

Resistors

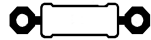

Bend the leads at a 90-degree angle to the resistor's body, then slip them into the holes on the board. Both leads are equivalent so it doesn't matter which way the resistor is rotated.

See the parts identification guide on the Tune In Tokyo web page for help with color codes.

5	1M resistor
5	10k resistor
2	2.2k resistor
2	4.7k resistor
1	1k resistor
1	22.1k resistor (blue)
2	23.7k resistor (blue)
2	30.9k resistor (blue)
2	57.6k resistor (blue)

Diode

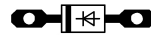

Orient the striped end of the diode to match the printing on the board.

1	1N4001 diode
---	--------------

Switches

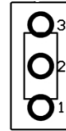

There are two SPDT slide switches. They mount in the middle of the cluster of four potentiometers.

2	SPDT slide switch
---	-------------------

Poly & Ceramic capacitors

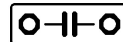

The polyester capacitor looks like a rectangular plastic box. The ceramic caps are orange and disc shaped. Both legs are equivalent so it doesn't matter which way they go in. *Install the 100n capacitor in the place marked 10n.*

1	100n polyester (previously 10n)
2	220p ceramic disc [221]
1	470p ceramic disc [471]

Electrolytic capacitors



The electrolytic capacitors are polarized. Make sure their long leg goes into the hole marked plus (+). Or, you can identify the negative side of the capacitor by the stripe printed on its side.

1	100u electrolytic
1	2.2u electrolytic
1	10u electrolytic
1	47u electrolytic

Visible LED



This LED is T1 (3mm) type and can be any color. Insert its short leg into the hole with the bar printed next to it. (The flat edge of the LED faces the bar.)

1	Visible LED
---	-------------

I can has chipz now plz?

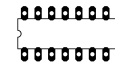

Install the four chips into their positions. Use a bright light to read the printing on the chips. Before you insert them, it helps to bend the leads inward slightly by pressing against a conductive surface like aluminum foil. This makes the rows of leads parallel and they will go into the holes easier. The chips must be inserted in the proper orientation! Align them so the text on the chips reads right side up like the "Tune In Tokyo" logo printed on the circuit board. Solder all of the leads.

chips

1	MC14584 (14 pin)
1	74HC594 (16 pin)
1	74HC4046 (16 pin)
1	TLC2262 (8 pin)

Voltage Regulator



This is a small 3-legged device that looks like a transistor. Insert it with its flat edge matching the printing on the board. It may have 7805 or LM2931AZ5 printed on it.

1	Voltage Regulator
---	-------------------

Potentiometers

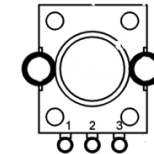

There are a total of five potentiometers. The Volume control can be either 5k or 10k type.

4	B500k pot
1	A5k or A10k pot

Output Jack

The jack mounts from the underside of the board and points outward. It is located underneath the Tune In Tokyo logo. Solder the leads in place.

1 1/4" Jack

Battery Snap

⊗ B-

⊙ B+

The battery snap solders to the two pads marked B+ and B-. The red lead goes to B+ and the black lead goes to B-. To help protect the wires from being accidentally pulled off the board, there is an extra hole drilled next to B+ and B-. Loop the battery wires through this hole twice and it will be an effective strain relief.

1 9V battery snap

My Legs My Legs!

Your kit needs its four legs to sit flat on a surface. Install the legs, made of plastic tubing, using the screws provided. To make tightening easier, grip the leg with pliers while you turn the screw.



Now's a good time to wash your hands if you have been using lead solder.



Now all of the parts should be in place and the unit is ready to test. Install the 9V battery and plug a 1/4" cable into the jack. The LED should be on. If it doesn't come on, it may be installed backwards. Plug the unit in to a mixer or guitar amp, turn up the volume on your Tune In Tokyo, and listen for sound.

Solutions

If you don't hear swirling frequencies, you have a problem or a dead battery. The first thing you can do is make sure all the parts are installed in the proper orientation. Check the photos on the Tune In Tokyo web page for reference. If that looks OK, you probably have a bad solder joint or a chip may be in the wrong location, or installed backwards.

Inspect all the solder joints and be sure there is no solder bridging adjacent points. Re-heat each joint with the soldering iron until you see the solder liquefy and become shiny all over - then remove the iron. You can add a little bit of fresh solder here if it looks like there may be too little.

makes the sound of tuning an old fashioned short wave radio

square wave oscillators

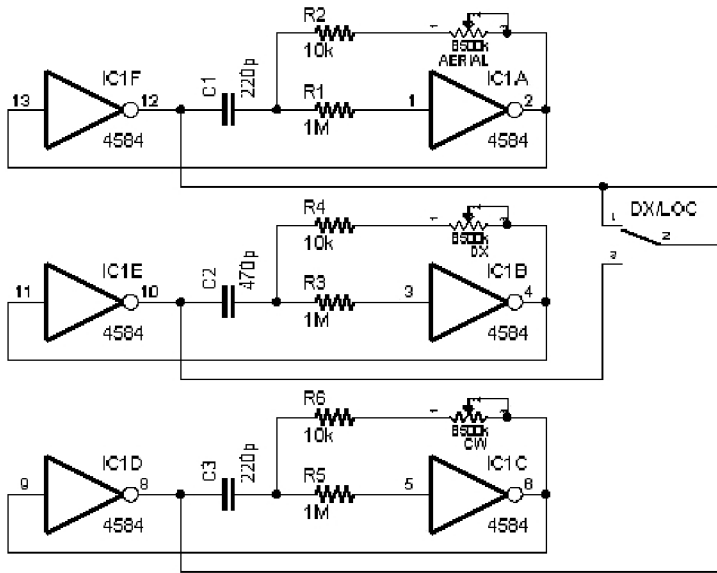

resistor values from digital sinewave generator Don Lancaster CMOS Cookbook pg 329

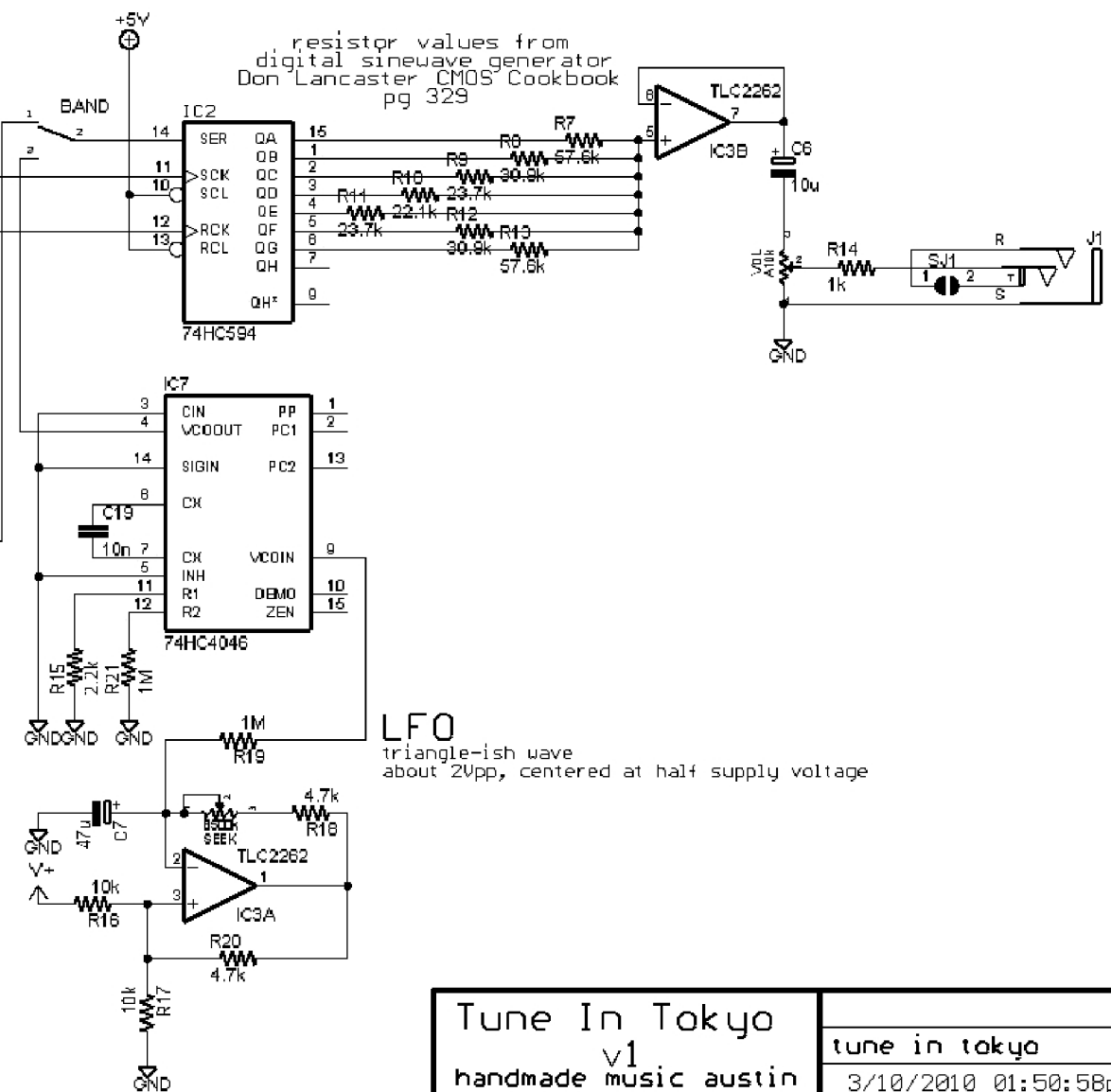

LFO
triangle-ish wave
about 2Vpp, centered at half supply voltage

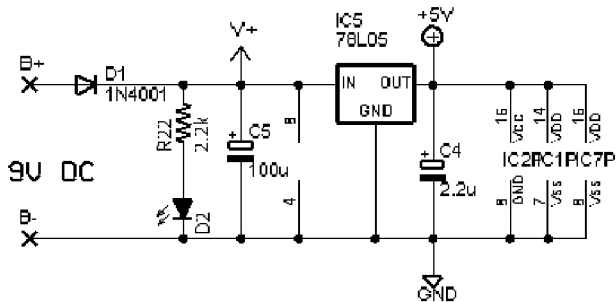

Tune In Tokyo	
v1	
handmade music austin	
by ericarcher.net	
tune in tokyo	
3/10/2010 01:50:58P	
Sheet: 1/1	

Tune In Tokyo Parts Identification Guide

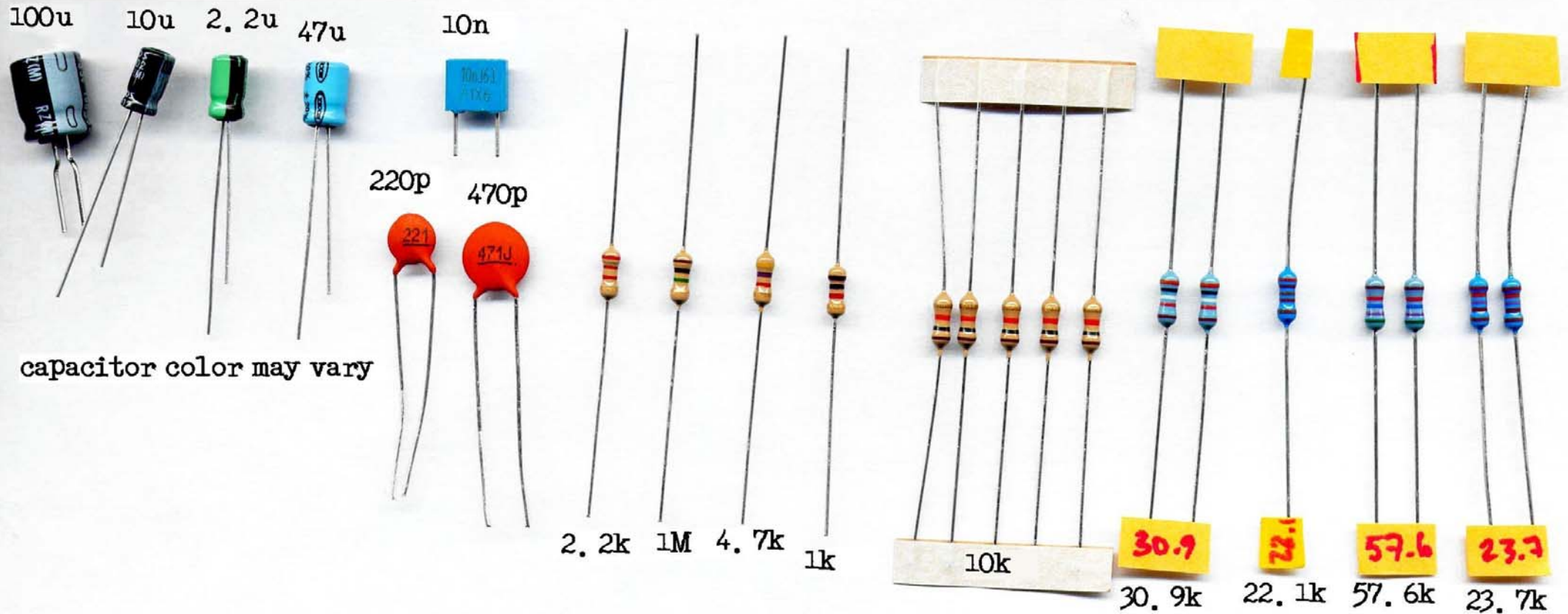

2.2k = Red, Red, Red, Gold
1M = Brown, Black, Green, Gold
4.7k = Yellow, Purple, Red, Gold
1k = Brown, Black, Red, Gold
10k = Brown, Black, Orange, Gold